

Threaded thermocouple With protection tube Model TC10-C

WIKA data sheet TE 65.03



for further approvals
see page 2

Applications

- Machine building, plant and vessel construction
- Energy and power plant technology
- Chemical industry
- Food and beverage industry
- Sanitary, heating and air-conditioning technology

Special features

- Sensor ranges from $-40 \dots +1,200 \text{ }^{\circ}\text{C}$ [$-40 \dots +2,192 \text{ }^{\circ}\text{F}$]
- With integrated fabricated protection tube
- Spring-loaded measuring insert (replaceable)
- Explosion-protected versions are available for many approval types (see page 2)



Model TC10-C with protection tube

Description

Thermocouples of this series are designed for screw-fitting directly into the process, mainly in vessels and pipelines. These thermometers are suitable for liquid and gaseous media under moderate mechanical load and normal chemical conditions.

The protection tube is fully welded and screwed into the connection head. The interchangeable measuring insert can be removed without taking out the complete sensor from the plant. This enables inspection, measuring equipment monitoring or, when servicing is necessary, replacement while the plant is running. The choice of standard lengths assists with short delivery times and the possibility of stocking spare parts.

Insertion length, process connection, protection tube design, connection head, type and number of sensors, accuracy and connection method can each be selected to suit the respective application.

A large number of different explosion protection approvals are available for the TC10-C.

Optionally we can fit transmitters from the WIKA range into the connection head of the TC10-C.

Explosion protection (option)







The permissible power, P_{max} , as well as the permissible ambient temperature, for the respective category can be seen on the certificate for hazardous areas or in the operating instructions.









Attention:

Only with the correspondingly suitable protective fitting is operation in dust Ex hazardous areas permissible.

Transmitters have own certificates for hazardous areas. The permissible ambient temperature ranges of the built-in transmitters can be taken from the corresponding transmitter operating instructions and approvals.

Approvals (explosion protection, further approvals)

| Logo | Description | Country |
|---|--|-----------------------------|
|   | EU declaration of conformity <ul style="list-style-type: none"> ■ EMC directive ¹⁾ EN 61326 emission (group 1, class B) and interference immunity (industrial application) ■ RoHS directive ■ ATEX directive (option) Hazardous areas <ul style="list-style-type: none"> - Ex i Zone 0 gas II 1G Ex ia IIC T1 ... T6 Ga Zone 1 mounting to zone 0 gas II 1/2G Ex ia IIC T1 ... T6 Ga/Gb Zone 1 gas II 2G Ex ia IIC T1 ... T6 Gb Zone 20 dust II 1D Ex ia IIIC T125 ... T65 °C Da Zone 21 mounting to zone 20 dust II 1/2D Ex ia IIIC T125 ... T65 °C Da/Db Zone 21 dust II 2D Ex ia IIIC T125 ... T65 °C Db - Ex e ²⁾ Zone 1 gas ³⁾ II 2G Ex eb IIC T1 ... T6 Gb ⁴⁾ Zone 2 gas II 3G Ex ec IIC T1 ... T6 Gc X Zone 21 dust ³⁾ II 2D Ex tb IIIC TX °C Db ⁴⁾ Zone 22 dust II 3D Ex tc IIIC TX °C Dc X - Ex n ²⁾ Zone 2 gas II 3G Ex nA IIC T1 ... T6 Gc X Zone 22 dust II 3D Ex tc IIIC TX °C Dc X | European Union |
|   | IECEx (option) - in conjunction with ATEX Hazardous areas <ul style="list-style-type: none"> - Ex i Zone 0 gas Ex ia IIC T1 ... T6 Ga Zone 1 mounting to zone 0 gas Ex ia IIC T1 ... T6 Ga/Gb Zone 1 gas Ex ia IIC T1 ... T6 Gb Zone 20 dust Ex ia IIIC T125 ... T65 °C Da Zone 21 mounting to zone 20 dust Ex ia IIIC T125 ... T65 °C Da/Db Zone 21 dust Ex ia IIIC T125 ... T65 °C Db | International |
|  | EAC (option) Hazardous areas <ul style="list-style-type: none"> - Ex i Zone 0 gas 0Ex ia IIC T6 ... T1 Ga X Zone 1 gas 1Ex ia IIC T6 ... T1 Gb X Zone 20 dust Ex ia IIIC T80 ... T440 °C Da X Zone 21 dust Ex ia IIIC T80 ... T440 °C Db X - Ex n Zone 2 gas 2Ex nA IIC T6 ... T1 Gc X | Eurasian Economic Community |
|  | Ex Ukraine (option) Hazardous areas <ul style="list-style-type: none"> - Ex i Zone 0 gas II 1G Ex ia IIC T1 ... T6 Ga Zone 1 mounting to zone 0 gas II 1/2G Ex ia IIC T1 ... T6 Ga/Gb Zone 1 gas II 2G Ex ia IIC T1 ... T6 Gb Zone 20 dust II 1D Ex ia IIIC T65 °C Da Zone 21 mounting to zone 20 dust II 1/2D Ex ia IIIC T65 °C Da/Db Zone 21 dust II 2D Ex ia IIIC T65 °C Db | Ukraine |

| Logo | Description | Country |
|---|---|-------------|
|  | INMETRO (option) Hazardous areas - Ex i Zone 0 gas Ex ia IIC T3 ... T6 Ga Zone 1 mounting to zone 0 gas Ex ia IIC T3 ... T6 Ga/Gb Zone 20 dust Ex ia IIIC T125 ... T65 °C Da Zone 21 mounting to zone 20 dust Ex ia IIIC T125 ... T65 °C Da/Db | Brazil |
|  | CCC (option) 4) Hazardous areas - Ex i Zone 0 gas Ex ia IIC T1 ~ T6 Ga Zone 1 gas Ex ia IIC T1 ~ T6 Gb Zone 1 mounting to zone 0 gas Ex ia IIC T1 ~ T6 Ga/Gb Zone 2 gas Ex ic IIC T1 ~ T6 Gc Zone 20 dust Ex iaD 20 T65/T95/T125 °C Zone 21 dust Ex iaD 21 T65/T95/T125 °C Zone 21 mounting to zone 20 dust Ex iaD 20/21 T65/T95/T125 °C | China |
|  | KCS - KOSHA (option) Hazardous areas - Ex i Zone 0 gas Ex ia IIC T4 ... T6 Zone 1 gas Ex ib IIC T4 ... T6 | South Korea |
| - | PESO (option) Hazardous areas - Ex i Zone 0 gas Ex ia IIC T1 ... T6 Ga Zone 1 mounting to zone 0 gas Ex ia IIC T1 ... T6 Ga/Gb Zone 1 gas Ex ia IIC T1 ... T6 Gb | India |
|  | GOST (option) Metrology, measurement technology | Russia |
|  | KazInMetr (option) Metrology, measurement technology | Kazakhstan |
| - | MTSCHS (option) Permission for commissioning | Kazakhstan |
|  | BelGIM (option) Metrology, measurement technology | Belarus |
|  | UkrSEPRO (option) Metrology, measurement technology | Ukraine |
|  | Uzstandard (option) Metrology, measurement technology | Uzbekistan |



1) Only for built-in transmitter

2) Only for connection head model BSZ or BSZ-H (see "Connection head")

3) Only for insulated thermocouples

4) Without transmitter

Manufacturer's information and certifications

| Logo | Description |
|---|---|
|  | SIL 2 Functional safety (only in conjunction with model T32 temperature transmitter) |
|  | NAMUR NE 024 Hazardous areas (Ex i) |

Instruments marked with "ia" may also be used in areas only requiring instruments marked with "ib" or "ic".
If an instrument with "ia" marking has been used in an area with requirements in accordance with "ib" or "ic", it can no longer be operated in areas with requirements in accordance with "ia" afterwards.

Approvals and certificates, see website

Sensor

Thermocouple per IEC 60584-1 or ASTM E230

Types K, J, E, N, T (single or dual thermocouple)

Measuring point

- Ungrounded (standard)
- Grounded

Sensor types

| Type | Validity limits of class accuracy | | | |
|------|-----------------------------------|-------------------|----------------|---------|
| | IEC 60584-1 | | ASTM E230 | |
| | Class 2 | Class 1 | Standard | Special |
| K | -40 ... +1,200 °C | -40 ... +1,000 °C | 0 ... 1,260 °C | |
| J | -40 ... +750 °C | -40 ... +750 °C | 0 ... 760 °C | |
| E | -40 ... +900 °C | -40 ... +800 °C | 0 ... 870 °C | |
| N | -40 ... +1,200 °C | -40 ... +1,000 °C | 0 ... 1,260 °C | |
| T | -40 ... +350 °C | | 0 ... 370 °C | |

The table shows the temperature ranges listed in the respective standards, in which the tolerance values (class accuracies) are valid.

The actual operating temperature of the thermometers is limited both by the maximum permissible working temperature and the diameter of the thermocouple and the MI cable, as well as by the maximum permissible working temperature of the thermowell material.

For detailed specifications for thermocouples, see IEC 60584-1 or ASTM E230 and Technical information IN 00.23 at www.wika.com.

Tolerance value

For the tolerance value of thermocouples, a cold junction temperature of 0 °C has been taken as the basis.

Electrical connection

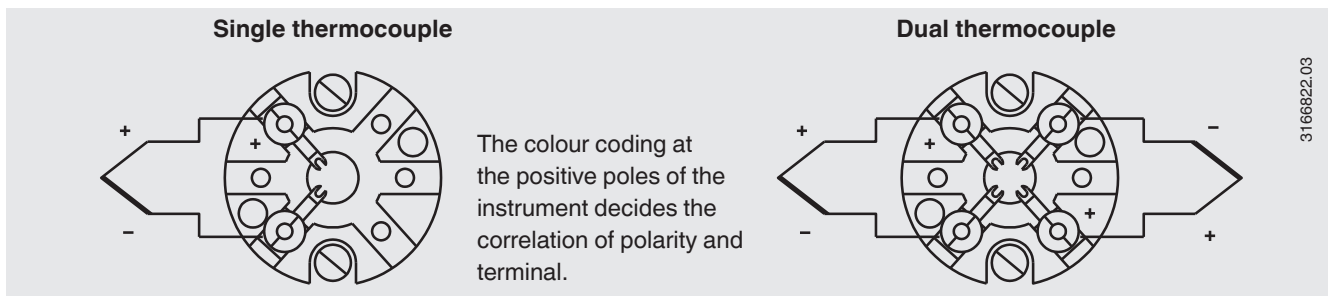

For the electrical connections of built-in temperature transmitters see the corresponding data sheets or operating instructions.

Connection head

■ European designs per EN 50446 / DIN 43735

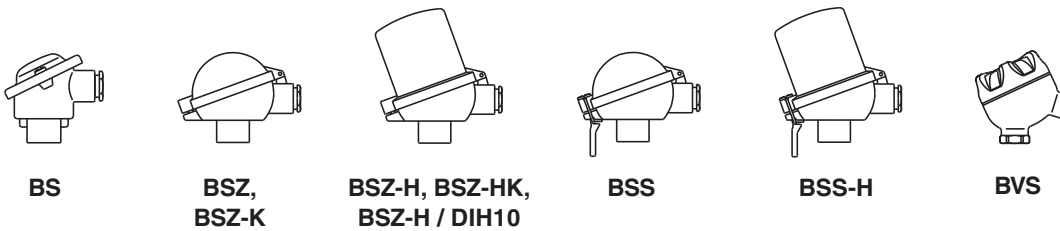

| Model | Material | Cable entry thread size | Ingress protection (max) ¹⁾ IEC/EN 60529 | Cap | Surface | Connection to neck tube |
|------------------------------------|-----------------|--|--|---|-----------------------------|-------------------------|
| BS | Aluminium | M20 x 1.5 or ½ NPT ³⁾ | IP65 ⁴⁾ | Flat cap with 2 screws | Blue, painted ⁵⁾ | M24 x 1.5, ½ NPT |
| BSZ | Aluminium | M20 x 1.5 or ½ NPT ³⁾ | IP65 ⁴⁾ | Spherical hinged cover with cylinder head screw | Blue, painted ⁵⁾ | M24 x 1.5, ½ NPT |
| BSZ-H | Aluminium | M20 x 1.5 or ½ NPT ³⁾ | IP65 ⁴⁾ | Raised hinged cover with cylinder head screw | Blue, painted ⁵⁾ | M24 x 1.5, ½ NPT |
| BSZ-H (2x cable outlet) | Aluminium | 2 x M20 x 1.5 or 2 x ½ NPT ³⁾ | IP65 ⁴⁾ | Raised hinged cover with cylinder head screw | Blue, painted ⁵⁾ | M24 x 1.5 |
| BSZ-H / DIH10 ²⁾ | Aluminium | M20 x 1.5 or ½ NPT ³⁾ | IP65 | Raised hinged cover with cylinder head screw | Blue, painted ⁵⁾ | M24 x 1.5, ½ NPT |
| BSS | Aluminium | M20 x 1.5 or ½ NPT ³⁾ | IP65 | Spherical hinged cover with clamping lever | Blue, painted ⁵⁾ | M24 x 1.5, ½ NPT |
| BSS-H | Aluminium | M20 x 1.5 or ½ NPT ³⁾ | IP65 | Raised hinged cover with clamping lever | Blue, painted ⁵⁾ | M24 x 1.5, ½ NPT |
| BVS | Stainless steel | M20 x 1.5 ³⁾ | IP65 | Precision-cast screw-on lid | Blank, electropolished | M24 x 1.5 |
| BSZ-K | Plastic | M20 x 1.5 or ½ NPT ³⁾ | IP65 | Spherical hinged cover with cylinder head screw | Black | M24 x 1.5 |
| BSZ-HK | Plastic | M20 x 1.5 or ½ NPT ³⁾ | IP65 | Raised hinged cover with cylinder head screw | Black | M24 x 1.5 |

| Model | Explosion protection | | | | | |
|------------------------------------|----------------------|----------------------------|--------------------------------|-------------------------|----------------------------|-----------------------|
| | Without | Ex i (gas) Zone 0, 1, 2 | Ex i (dust) Zone 20, 21, 22 | Ex e (gas) Zone 1, 2 | Ex t (dust) Zone 21, 22 | Ex nA (gas) Zone 2 |
| BS | x | x | x | - | - | - |
| BSZ | x | x | x | x ⁶⁾ | x ⁶⁾ | x ⁷⁾ |
| BSZ-H | x | x | x | x ⁶⁾ | x ⁶⁾ | x ⁷⁾ |
| BSZ-H (2x cable outlet) | x | x | x | x ⁶⁾ | x ⁶⁾ | x ⁷⁾ |
| BSZ-H / DIH10 ¹⁾ | x | x | - | - | - | - |
| BSS | x | x | - | - | - | - |
| BSS-H | x | x | - | - | - | - |
| BVS | x | x | - | - | - | - |
| BSZ-K | x | x | - | - | - | - |
| BSZ-HK | x | x | - | - | - | - |

1) IP ingress protection of the connection head. The IP ingress protections of the complete instrument TC10-C must not inevitably correspond to the connection head.

2) LED display DIH10

3) Standard (others on request)

4) Ingress protections, which describe temporary or lasting submersion, available on request

5) RAL 5022

6) Only ATEX

7) Only ATEX and EAC-Ex

■ North American designs



KN4-A
KN4-P

| Model | Material | Cable entry thread size | Ingress protection (max.) ¹⁾ IEC/EN 60529 | Cover / Cap | Surface | Connection to neck tube |
|---------------------|---------------|----------------------------------|---|--------------|-----------------------------|-------------------------|
| KN4-A | Aluminium | ½ NPT or M20 x 1.5 ²⁾ | IP65 | Screw-on lid | Blue, painted ³⁾ | M24 x 1.5, ½ NPT |
| KN4-P ⁴⁾ | Polypropylene | ½ NPT | IP65 | Screw-on lid | White | ½ NPT |

| Model | Explosion protection | | | | | |
|---------------------|----------------------|----------------------------|--------------------------------|-------------------------|----------------------------|-----------------------|
| | Without | Ex i (gas) Zone 0, 1, 2 | Ex i (dust) Zone 20, 21, 22 | Ex e (gas) Zone 1, 2 | Ex t (dust) Zone 21, 22 | Ex nA (gas) Zone 2 |
| KN4-A | x | x | - | - | - | - |
| KN4-P ⁴⁾ | x | - | - | - | - | - |

1) IP ingress protection of the connection head. The IP ingress protections of the complete instrument TC10-C must not inevitably correspond to the connection head.

2) Standard (others on request)

3) RAL 5022

4) On request

Connection head with digital display



Connection head BSZ-H with LED display model DIH10
see data sheet AC 80.11

To operate the digital displays, a transmitter with a 4 ... 20 mA output is always required.

Cable entry



Standard



Plastic



Brass,
nickel-plated



Stainless steel



Junction box,
M12 x 1 (4-pin)



Plain
threaded

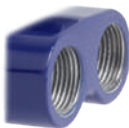

2 x plain
threaded



Sealing plugs for
transport

The pictures show examples of connection heads.

| Cable entry | Cable entry thread size | Min./max. ambient temperature |
|---|-------------------------|--|
| Standard cable entry ¹⁾ | M20 x 1.5 or ½ NPT | -40 ... +80 °C |
| Plastic cable gland (cable Ø 6 ... 10 mm) ¹⁾ | M20 x 1.5 or ½ NPT | -40 ... +80 °C |
| Plastic cable gland (cable Ø 6 ... 10 mm), Ex e ¹⁾ | M20 x 1.5 or ½ NPT | -20 ... +80 °C (standard) -40 ... +70 °C (option) |
| Nickel-plated brass cable gland (cable Ø 6 ... 12 mm) | M20 x 1.5 or ½ NPT | -40 ... +80 °C |
| Stainless steel cable gland (cable Ø 7 ... 12 mm) | M20 x 1.5 or ½ NPT | -40 ... +80 °C |
| Plain threaded | M20 x 1.5 or ½ NPT | - |
| 2 x M20 x 1.5 ²⁾ | 2 x M20 x 1.5 | - |
| Junction box M12 x 1 (4-pin) ³⁾ | M20 x 1.5 | -40 ... +80 °C |
| Sealing plugs for transport | M20 x 1.5 or ½ NPT | -40 ... +80 °C |

| Cable entry | Colour | Ingress protection (max.) ⁴⁾ IEC/EN 60529 | Explosion protection | | | | | |
|--|---------------|---|--------------------------------------|-------------------------------|-----------------------------------|----------------------------|-------------------------------|--------------------------|
| | | | without | Ex i (gas) Zone 0, 1, 2 | Ex i (dust) Zone 20, 21, 22 | Ex e (gas) Zone 1, 2 | Ex t (dust) Zone 21, 22 | Ex nA (gas) Zone 2 |
| Standard cable entry ¹⁾ | Blank | IP65 | x | x | - | - | - | - |
| Plastic cable gland ¹⁾ | Black or grey | IP66 ⁵⁾ | x | x | - | - | - | - |
| Plastic cable gland, Ex e ¹⁾ | Light blue | IP66 ⁵⁾ | x | x | x | - | - | - |
| Plastic cable gland, Ex e ¹⁾ | Black | IP66 ⁵⁾ | x | x | x | x | x | x |
| Nickel-plated brass cable gland | Blank | IP66 ⁵⁾ | x | x | x | - | - | - |
| Nickel-plated brass cable gland, Ex e | Blank | IP66 ⁵⁾ | x | x | x | x | x | x |
| Stainless steel cable gland | Blank | IP66 ⁵⁾ | x | x | x | - | - | - |
| Stainless steel cable gland, Ex e | Blank | IP66 ⁵⁾ | x | x | x | x | x | x |
| Plain threaded | - | IP00 | x | x | x ⁷⁾ | x ⁷⁾ | x ⁷⁾ | x ⁷⁾ |
| 2 x M20 x 1.5 ²⁾ | - | IP00 | x | x | x ⁷⁾ | x ⁷⁾ | x ⁷⁾ | x ⁷⁾ |
| Junction box M12 x 1 (4-pin) ³⁾ | - | IP65 | x | x ⁶⁾ | x ⁶⁾ | - | - | - |
| Sealing plugs for transport | Transparent | - | not applicable, transport protection | | | | | |

1) Not available for BVS connection head

2) Only for BSZ-H connection head

3) Not available for ½ NPT thread size cable entry

4) IP ingress protection of the cable gland. The IP ingress protections of the complete instrument TC10-C must not inevitably correspond to the cable gland.

5) Ingress protections, which describe temporary or continuous immersion, available on request

6) With appropriate mating connector connected

7) Suitable cable gland required for operation

Ingress protection per IEC/EN 60529

Degrees of protection against solid foreign bodies (defined by the first index number)

| First index number | Degree of protection / short description | Test parameter |
|--------------------|--|------------------|
| 5 | Dust-protected | per IEC/EN 60529 |
| 6 | Dust-tight | per IEC/EN 60529 |

Degrees of protection against water (defined by the second index number)

| Second index number | Degree of protection / short description | Test parameter |
|---------------------|--|------------------|
| 4 | Protected against splash water | per IEC/EN 60529 |
| 5 | Protected against water jets | per IEC/EN 60529 |
| 6 | Protected against strong water jets | per IEC/EN 60529 |
| 7 ¹⁾ | Protected against the effects of temporary immersion in water | per IEC/EN 60529 |
| 8 ¹⁾ | Protected against the effects of continuous immersion in water | by agreement |

1) Ingress protections, describing temporary or permanent immersion, on request

Standard ingress protection of model TC10-C is IP65.

The stated degrees of protection apply under the following conditions:

- Use of a suitable cable gland
- Use of a cable cross-section appropriate for the gland or select the appropriate cable gland for the available cable
- Adhere to the tightening torques for all threaded connections

Transmitter

Mounting onto the measuring insert

With mounting on the measuring insert, the transmitter replaces the terminal block and is fixed directly to the terminal plate of the measuring insert.

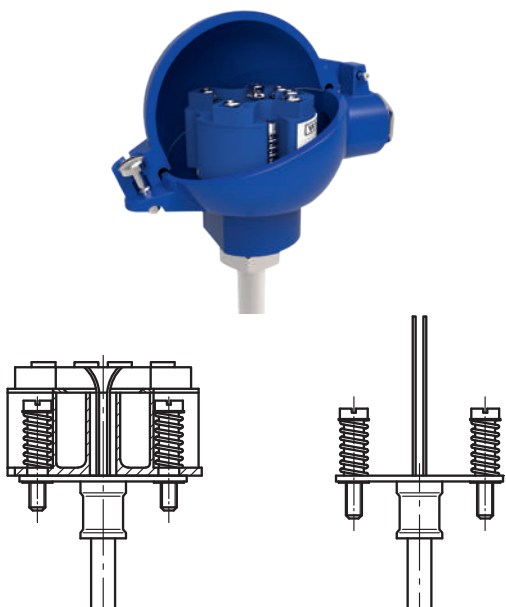

Fig. left: Measuring insert with mounted transmitter (here: model T32)
Fig. right: Measuring insert prepared for transmitter mounting

Mounted within the cap of the connection head

Mounting the transmitter in the cap of the connection head is preferable to mounting it on the measuring insert. With this type of mounting, for one, a better thermal insulation is ensured, and in addition, exchange and mounting for servicing is simplified.



Transmitter models



| Output signal 4 ... 20 mA, HART® protocol | | |
|---|---------------|---------------|
| Transmitter (selectable versions) | Model T16 | Model T32 |
| Data sheet | TE 16.01 | TE 32.04 |
| Output | | |
| 4 ... 20 mA | x | x |
| HART® protocol | - | x |
| Input | | |
| Thermocouples IEC 60584-1 | K, J, E, N, T | K, J, E, N, T |
| Explosion protection | Optional | Optional |

Possible mounting positions for transmitters

| Connection head | T16 | T32 |
|-------------------------|-----|-----|
| BS | ○ | - |
| BSZ, BSZ-K | ○ | ○ |
| BSZ-H, BSZ-HK | ● | ● |
| BSZ-H (2x cable outlet) | ● | ● |
| BSZ-H / DIH10 | ○ | ○ |
| BSS | ○ | ○ |
| BSS-H | ● | ● |
| BVS | ○ | ○ |
| KN4-A / KN4-P | ○ | ○ |

○ Mounted instead of terminal block ● Mounted within the cap of the connection head – Mounting not possible

The mounting of a transmitter on the measuring insert is possible with all the connection heads listed here. The fitting of a transmitter in the (screw) cap of a North American design connection head is not possible.

Mounting of 2 transmitters on request.

For a correct determination of the overall measuring deviation, the sensor and transmitter measuring deviations must be added.

Functional safety (option) with temperature transmitter model T32



In safety-critical applications, the entire measuring chain must be taken into consideration in terms of the safety parameters. The SIL classification allows the assessment of the risk reduction reached by the safety installations.

For detailed specifications, see Technical information IN 00.19 at www.wika.com.

Selected TC10-C thermocouples, in combination with a suitable temperature transmitter (e.g. model T32.1S, TÜV certified SIL version for protection systems developed in accordance with IEC 61508), are suitable as sensors for safety functions to SIL 2.

Components model TC10-C

Process connection: Mounting thread, firmly welded

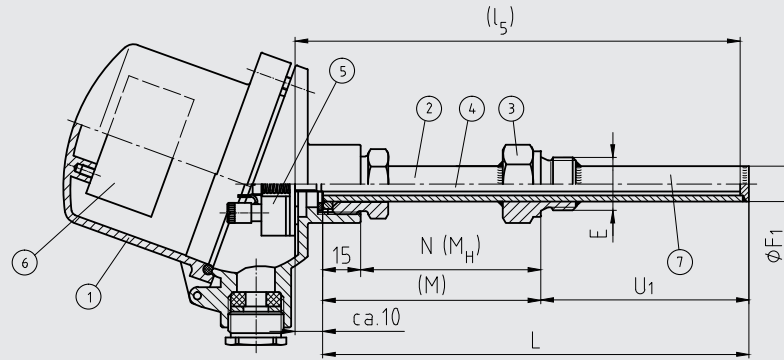

3175431.07

Process connection: Compression fitting

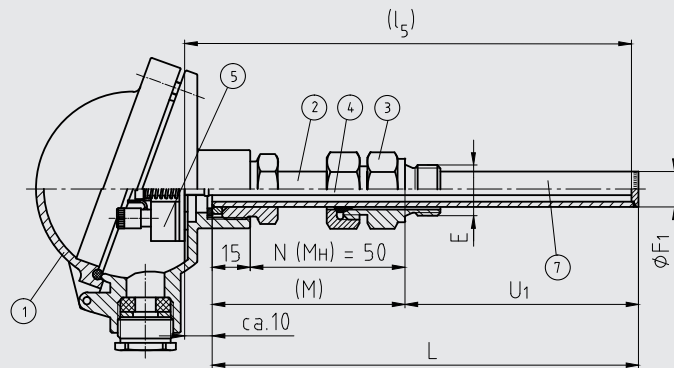

Legend:

- | | |
|---------------------------------------|---|
| ① Connection head | (L) Overall length protection tube |
| ② Neck tube | l ₅ Measuring insert length |
| ③ Process connection | U ₁ Protection tube insertion length per DIN 43772 |
| ④ Measuring insert (TC10-A) | Ø F ₁ Protection tube diameter |
| ⑤ Terminal block/transmitter (option) | E Mounting thread |
| ⑥ Transmitter (option) | N (M _H) Neck length |
| ⑦ Protection tube | (M) Neck tube length |

Fig. with parallel or tapered thread see chapter "Protection tube"

Protection tube

Protection tube designs

Protection tube, straight, mounting thread, form 2G DIN 43772

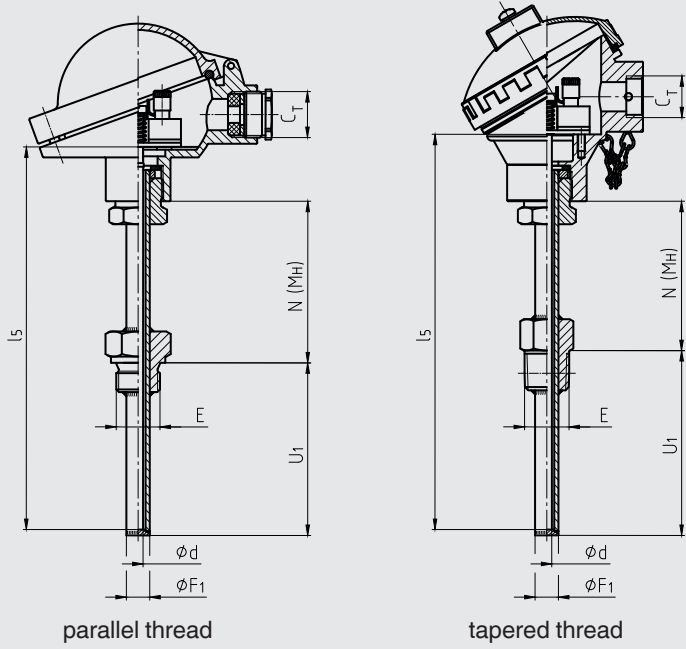

14126798.02

Protection tube, straight, plain, form 2 DIN 43772, with/without compression fitting

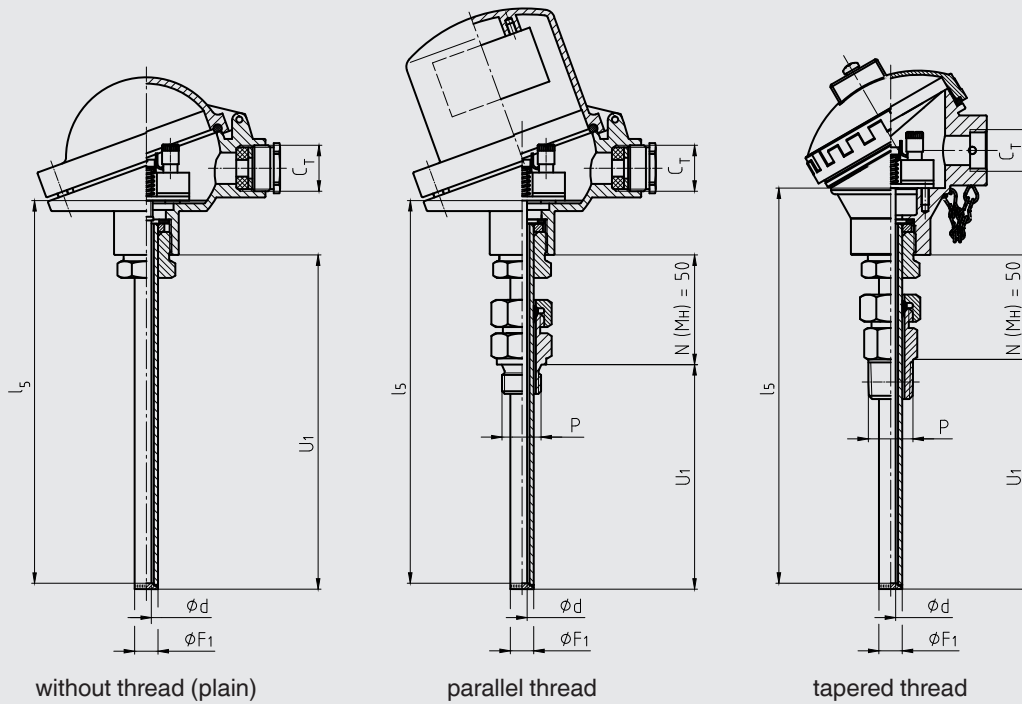

14126798.02

Legend:

| | | | |
|-----------|-------------------------|------------|-------------------------------------|
| U_1 | Insertion length | ϕF_1 | Protection tube diameter |
| l_s | Measuring insert length | E | Mounting thread |
| $N (M_H)$ | Neck length | ϕd | Measuring insert diameter |
| C_T | Thread cable entry | P | Compression fitting mounting thread |

The pictures show examples of connection heads.

Protection tube, tapered, mounting thread, form 3G DIN 43772

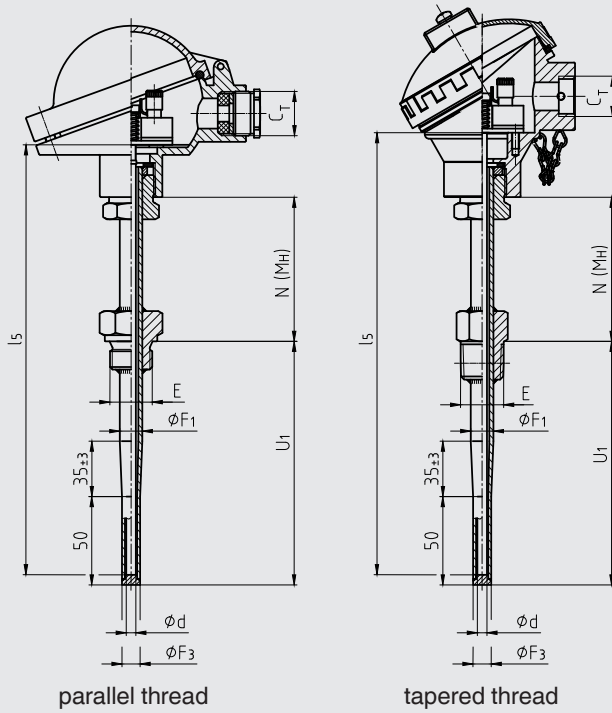

14126834.01

Protection tube, tapered, plain, form 3 DIN 43772, with/without compression fitting

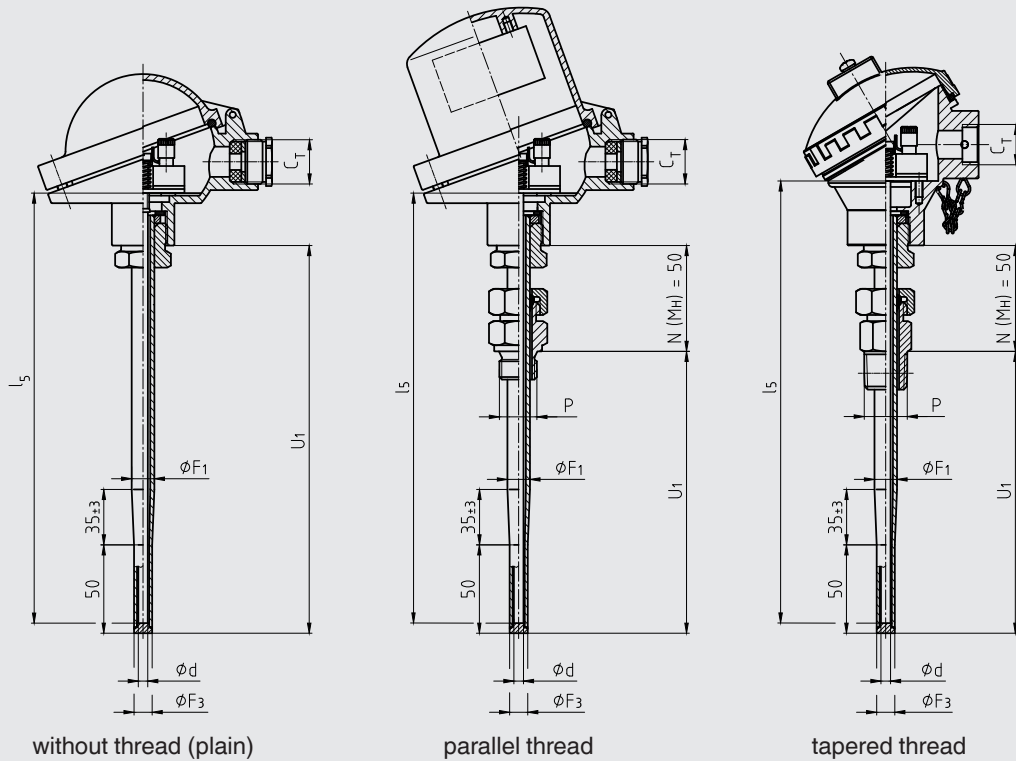

14126834.01

Legend:

- | | | | |
|-----------------|--------------------------|-----------------|-------------------------------------|
| U_1 | Insertion length | $\text{Ø } F_3$ | Diameter of protection tube tip |
| l_s | Measuring insert length | E | Mounting thread |
| $N (M_H)$ | Neck length | $\text{Ø } d$ | Measuring insert diameter |
| C_T | Thread cable entry | P | Compression fitting mounting thread |
| $\text{Ø } F_1$ | Protection tube diameter | | |

The pictures show examples of connection heads.

Protection tube, tapered, weld-on solid tip, mounting thread, non-standard design

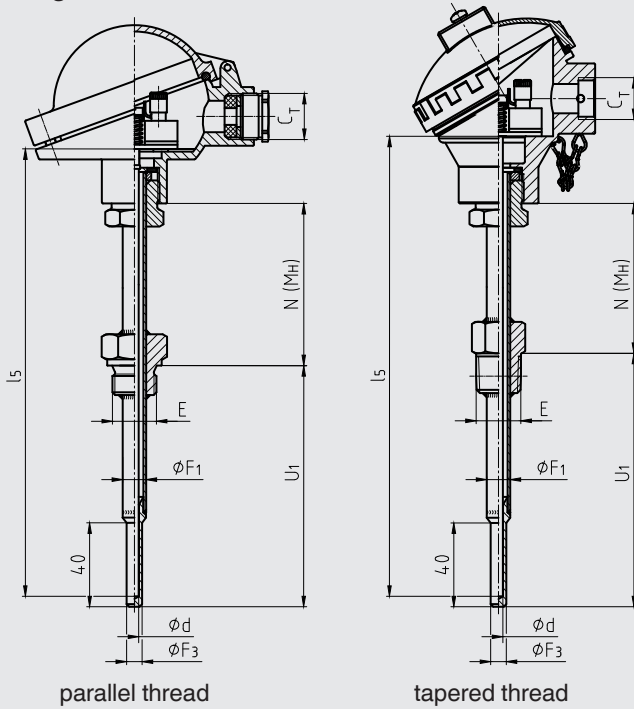

parallel thread

tapered thread

Protection tube, tapered, weld-on solid tip, plain, with/without compression fitting

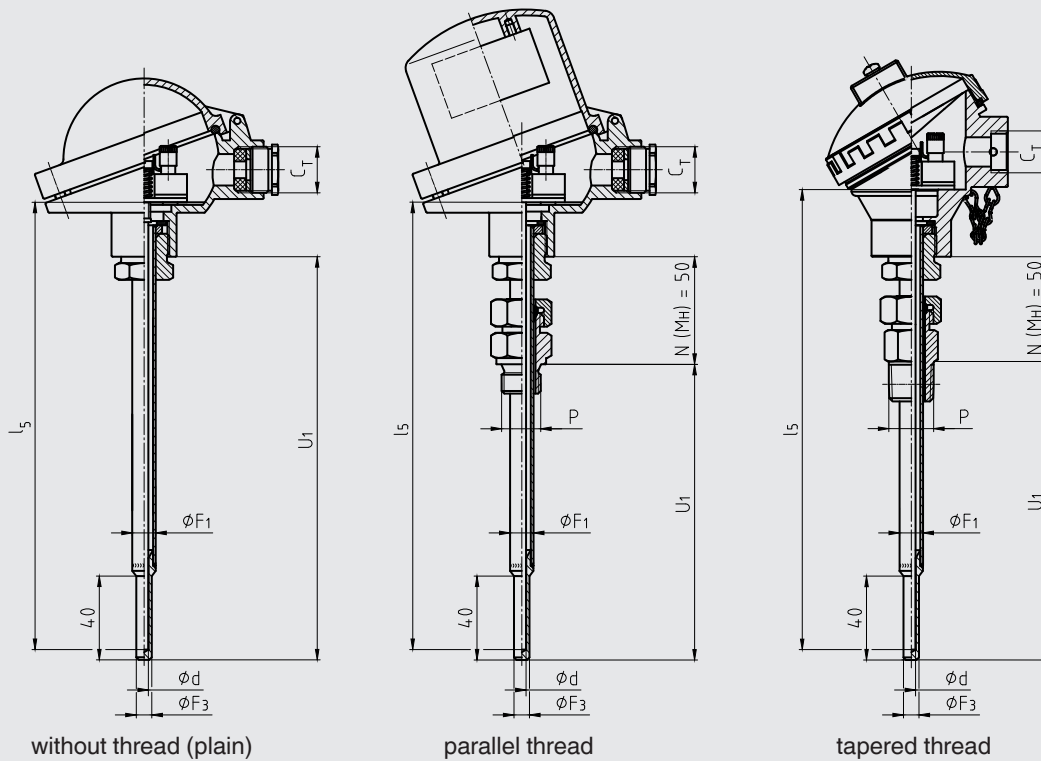

without thread (plain)

parallel thread

tapered thread

Legend:

- | | | | |
|-----------|-------------------------|-------------------|-------------------------------------|
| U_1 | Insertion length | $\varnothing F_1$ | Protection tube diameter |
| l_5 | Measuring insert length | $\varnothing F_3$ | Diameter of protection tube tip |
| $N (M_H)$ | Neck length | E | Mounting thread |
| K_E | 1/2 NPT: 8.13 mm | $\varnothing d$ | Measuring insert diameter |
| | 3/4 NPT: 8.61 mm | P | Compression fitting mounting thread |
| C_T | Thread cable entry | | |

The pictures show examples of connection heads.

Protection tube versions

The protection tubes are made of drawn tube with a welded bottom and are screwed into the connection head with a rotatable threaded connection (male nut). By loosening this male nut, the connection head, and thus the cable outlet, can be adjusted to the desired position. The process connection is welded on to customer specification at the factory. This determines the insertion length. Insertion lengths to DIN standards are preferable.

The immersion depth into the process medium should be at least 10 times the protection tube outer diameter.

For replacement requirements use model TW35 protection tube.

| Protection tube per DIN 43772 | Protection tube diameter | Process connection | Suitable for measuring insert diameter | Connection to head | Material | |
|--|---|---|--|---|----------|--------------------------|
| Straight, form 2G, mounting thread | 9 x 1 mm | G 1/4 B, mounting thread | 6 mm | M24 x 1.5 (rotatable threaded connection, male nut) | 1.4571 | |
| | | G 1/2 B, mounting thread | | | | |
| | | G 3/4 B, mounting thread | | | | |
| | | G 1 B, mounting thread | | | | |
| | | M18 x 1.5, mounting thread | | | | |
| | | M20 x 1.5, mounting thread | | | | |
| | | M27 x 2, mounting thread | | | | |
| | | 1/2 NPT, mounting thread | | | | |
| | | 3/4 NPT, mounting thread | | | | |
| | 11 x 2 mm 12 x 2.5 mm | G 1/2 B, mounting thread | 6 mm | | | |
| | | G 3/4 B, mounting thread | | | | |
| | | G 1 B, mounting thread | | | | |
| | | M18 x 1.5, mounting thread | | | | |
| | | M20 x 1.5, mounting thread | | | | |
| | | M27 x 2, mounting thread | | | | |
| | | 1/2 NPT, mounting thread | | | | |
| | | 3/4 NPT, mounting thread | | | | |
| | | 14 x 2.5 mm | | | | G 1/2 B, mounting thread |
| | G 3/4 B, mounting thread | | | | | |
| | G 1 B, mounting thread | | | | | |
| | M18 x 1.5, mounting thread | | | | | |
| | M20 x 1.5, mounting thread | | | | | |
| | M27 x 2, mounting thread | | | | | |
| | 1/2 NPT, mounting thread | | | | | |
| | 3/4 NPT, mounting thread | | | | | |
| | Tapered, form 3G, mounting thread | | 12 x 2.5 mm, tapered to 9 mm | | | G 1/2 B, mounting thread |
| | | G 3/4 B, mounting thread | | | | |
| G 1 B, mounting thread | | | | | | |
| M18 x 1.5, mounting thread | | | | | | |
| M20 x 1.5, mounting thread | | | | | | |
| M27 x 2, mounting thread | | | | | | |
| 1/2 NPT, mounting thread | | | | | | |
| 3/4 NPT, mounting thread | | | | | | |
| Straight, plain, form 2, with/without compression fitting | | 9 x 1 mm 11 x 2 mm 12 x 2.5 mm | | G 1/2 B compression fitting (metal ferrule) | 6 mm | |
| | 1/2 NPT compression fitting (metal ferrule) | | | | | |
| | Without threaded connection, plain | | | | | |
| Tapered, plain, form 3, with/without compression fitting | 12 x 2.5 mm, tapered to 9 mm | G 1/2 B compression fitting (metal ferrule) | 6 mm | | | |
| | | 1/2 NPT compression fitting (metal ferrule) | | | | |
| | | Without threaded connection, plain | | | | |

other versions on next page

| Tapered protection tube, non-standard | Protection tube diameter | Process connection | Suitable for measuring insert diameter | Connection to head | Material | | | | | |
|--|--|--|--|---|----------|----------------------------|---|------------------------------------|--|--|
| Tapered, weld-on solid tip, mounting thread | 9 x 1 mm, tapered to 6 mm | G 1/4 B, mounting thread | 3 mm | M24 x 1.5 (rotatable threaded connection, male nut) | 1.4571 | | | | | |
| | | G 1/2 B, mounting thread | | | | | | | | |
| | | G 3/4 B, mounting thread | | | | | | | | |
| | | G 1 B, mounting thread | | | | | | | | |
| | | M18 x 1.5, mounting thread | | | | | | | | |
| | | M20 x 1.5, mounting thread | | | | | | | | |
| | | M27 x 2, mounting thread | | | | | | | | |
| | | 1/2 NPT, mounting thread | | | | | | | | |
| | | 3/4 NPT, mounting thread | | | | | | | | |
| | 11 x 2 mm, tapered to 6 mm 12 x 2.5 mm, tapered to 6 mm | G 1/2 B, mounting thread | | | | | | | | |
| | | G 3/4 B, mounting thread | | | | | | | | |
| | | G 1 B, mounting thread | | | | | | | | |
| | | M14 x 1.5, mounting thread | | | | | | | | |
| | | M18 x 1.5, mounting thread | | | | | | | | |
| | | M20 x 1.5, mounting thread | | | | | | | | |
| | | 1/2 NPT, mounting thread | | | | | | | | |
| | | 3/4 NPT, mounting thread | | | | | | | | |
| | | Tapered, weld-on solid tip, plain, with/without compression fitting | | | | 9 x 1 mm, tapered to 6 mm | G 1/2 B compression fitting (metal ferrule) | Without threaded connection, plain | | |
| | | | | | | 11 x 2 mm, tapered to 6 mm | 1/2 NPT compression fitting (metal ferrule) | | | |
| 12 x 2.5 mm, tapered to 6 mm | | | | | | | | | | |

| Straight protection tube, non-standard | Protection tube diameter | Process connection | Suitable for measuring insert diameter | Connection to head | Material |
|--|--------------------------|----------------------------|--|---|---------------------------|
| Straight, mounting thread | 6 x 1 mm 8 x 1 mm | G 1/4 B, mounting thread | 3 mm | M24 x 1.5 (rotatable threaded connection, male nut) | 1.4571 316L (8 x 1 mm) |
| | | G 1/2 B, mounting thread | | | |
| | | M18 x 1.5, mounting thread | | | |
| | | M20 x 1.5, mounting thread | | | |
| | | 1/2 NPT, mounting thread | | | |
| | 10 x 1 mm 10 x 1.5 mm | G 1/2 B, mounting thread | 6 mm | | 316L |
| | | G 3/4 B, mounting thread | | | |
| | | G 1 B, mounting thread | | | |
| | | M18 x 1.5, mounting thread | | | |
| | | M20 x 1.5, mounting thread | | | |
| | | M27 x 2, mounting thread | | | |
| | | 1/2 NPT, mounting thread | | | |
| | 12 x 1 mm 12 x 1.5 mm | G 1/2 B, mounting thread | 8 mm (6 mm with sleeve) | | 316L |
| | | G 3/4 B, mounting thread | | | |
| | | G 1 B, mounting thread | | | |
| | | M18 x 1.5, mounting thread | | | |
| | | M20 x 1.5, mounting thread | | | |
| | | M27 x 2, mounting thread | | | |
| | | 1/2 NPT, mounting thread | | | |
| 3/4 NPT, mounting thread | | | | | |

other versions on next page

| Straight protection tube, non-standard | Protection tube diameter | Process connection | Suitable for measuring insert diameter | Connection to head | Material |
|---|--|---|--|---|---------------------------|
| Straight, plain, with/without compression fitting | 6 x 1 mm 8 x 1 mm | G 1/2 B compression fitting (metal ferrule) | 3 mm | M24 x 1.5 (rotatable threaded connection, male nut) | 1.4571 316L (8 x 1 mm) |
| | | 1/2 NPT compression fitting (metal ferrule) | | | |
| | | Without threaded connection, plain | | | |
| | 9 x 1 mm 10 x 1 mm 10 x 1.5 mm 12 x 1 mm 12 x 1.5 mm | G 1/2 B compression fitting (metal ferrule) | 6 mm | | 1.4571 (9 x 1 mm) 316L |
| | | 1/2 NPT compression fitting (metal ferrule) | | | |
| | | Without threaded connection, plain | | | |

Insertion lengths

| Protection tube design | Standard insertion length | Min./max. insertion length |
|--|---------------------------|----------------------------|
| Straight, mounting thread, form 2G DIN 43772 | 160, 250, 400 mm | 50 mm / 4,000 mm |
| Tapered, mounting thread, form 3G DIN 43772 | 160, 220, 280 mm | 110 mm / 4,000 mm |
| Straight, plain, with/without compression fitting, form 2 DIN 43772 | - | 50 mm / 4,000 mm |
| Tapered, plain, with/without compression fitting, form 3 DIN 43772 | - | 110 mm / 4,000 mm |
| Tapered, weld-on solid tip, mounting thread, non-standard design | 160, 250, 400 mm | 75 mm / 4,000 mm |
| Tapered, plain, weld-on solid tip, with/without compression fitting, non-standard design | - | 75 mm / 4,000 mm |

Neck lengths

| Protection tube design | Standard neck length | Min./max. neck length |
|---|----------------------|-----------------------|
| Straight, mounting thread, form 2G DIN 43772 | 130 mm | 30 mm / 1,000 mm |
| Tapered, mounting thread, form 3G DIN 43772 | 132 mm | 30 mm / 1,000 mm |
| Straight, plain, with compression fitting, form 2 DIN 43772 | 50 mm | 50 mm |
| Straight, plain, without compression fitting, form 2 DIN 43772 | - | - |
| Tapered, plain, with compression fitting, form 3 DIN 43772 | 50 mm | 50 mm |
| Tapered, plain, without compression fitting, form 3 DIN 43772 | - | - |
| Tapered, weld-on solid tip, mounting thread, non-standard design | 130 mm | 30 mm / 1,000 mm |
| Tapered, weld-on solid tip, with compression fitting, non-standard design | 50 mm | 50 mm |
| Tapered, weld-on solid tip, without process connection, non-standard design | - | - |

The neck tube is screwed into the connection head. The neck length depends on the intended use. Usually an isolation is bridged by the neck tube. Also, in many cases, the neck tube serves as a cooling extension between the connection head and the medium, in order to protect any possible built-in transmitter from high medium temperatures.

Other versions on request

Measuring insert

Within the TC10-C, the measuring insert of model TC10-A is fitted.

The replaceable measuring insert is made of a vibration-resistant, sheathed measuring cable (MI cable).



Measuring insert for thermocouple, model TC10-A

Only correct measuring insert length and correct measuring insert diameter ensure sufficient heat transfer from protection tube to the measuring insert.

The bore diameter of the protection tube should be a max. 1 mm larger than the measuring insert diameter. Gaps of more than 0.5 mm between protection tube and the measuring insert will have a negative effect on the heat transfer, and they will result in unfavourable response behaviour of the thermometer.

When fitting the measuring insert into a protection tube, it is very important to determine the correct insertion length (= protection tube length for bottom thicknesses of ≤ 5.5 mm). In order to ensure that the measuring insert is firmly pressed down onto the bottom of the protection tube, the insert must be spring-loaded (spring travel: max. 10 mm).

Material

| | |
|------------------------|---------------------|
| Sheath material | Ni alloy: alloy 600 |
|------------------------|---------------------|

Other sheath materials on request

Dimensions in mm

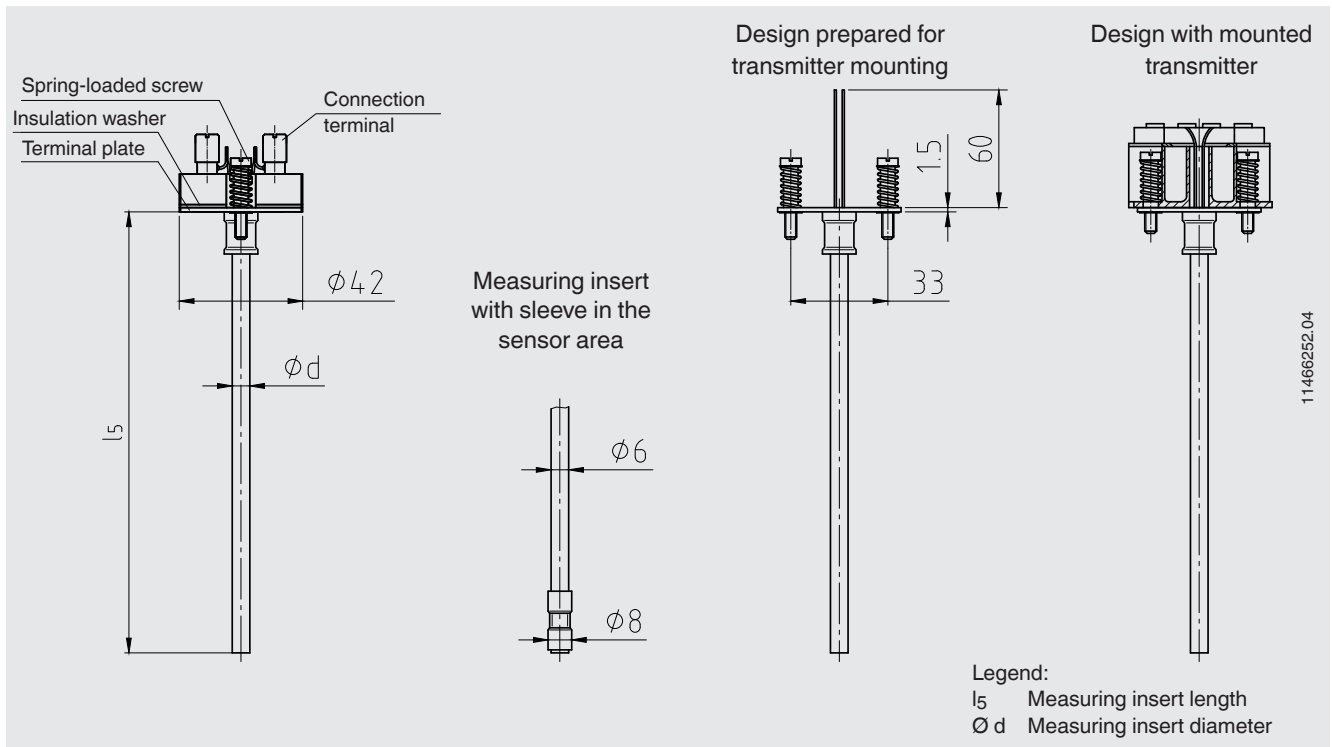

| Measuring insert length l_5 in mm | Tolerance in mm |
|-------------------------------------|-----------------|
| 75 ... 825 | +2 0 |
| > 825 | +3 0 |

| Measuring insert diameter ϕd in mm | Index per DIN 43735 | Tolerance in mm | |
|--|---------------------|-----------------|---|
| 3 ¹⁾ | Standard | 30 | 3 ± 0.05 |
| 6 | Standard | 60 | $6 \begin{smallmatrix} 0 \\ -0.1 \end{smallmatrix}$ |
| 8 (6 mm with sleeve) | Standard | - | $8 \begin{smallmatrix} 0 \\ -0.1 \end{smallmatrix}$ |
| 8 | Standard | 80 | $8 \begin{smallmatrix} 0 \\ -0.1 \end{smallmatrix}$ |
| 1/8 in [3.17 mm] 1/4 in [6.35 mm] 3/8 in [9.53 mm] | Option, on request | - | - |

Operating conditions

The replaceable measuring insert is made of a vibration-resistant, sheathed measuring cable (MI cable).
Standard vibration resistance: 50 g (sensor tip)

Max. process temperature, process pressure

Depending on:

- Load diagram DIN 43772
- Protection tube design
 - Dimensions
 - Material
- Process conditions
 - Flow rate
 - Medium density

Ambient and storage temperature

-40 ... +80 °C

Other ambient and storage temperatures on request

Thermowell calculation

With critical operating conditions, a thermowell calculation in accordance with Dittrich/Klotter is recommended as a WIKA engineering service.

Note: ASME PTC 19.3 TW-2016 is not applicable for the TC10-C.

For further information, see Technical information IN 00.15 "Strength calculation for thermowells".

Certificates (option)

| Certification type | Measurement accuracy | Material certificate ¹⁾ |
|-----------------------------------|----------------------|------------------------------------|
| 2.2 test report | x | x |
| 3.1 inspection certificate | x | x |
| DKD/DAkkS calibration certificate | x | - |

1) Protection tubes have their own material certificates

The different certifications can be combined with each other.

For calibration, the measuring insert is removed from the thermometer. The minimum length (metal part of the probe) for carrying out a measurement accuracy test 3.1 or DKD/DAkkS is 100 mm.

Calibration of shorter lengths on request.

Ordering information

Model / Explosion protection / Further approvals, certificates / Sensor / Accuracy class, range of use of the sensor / Connection housing / Cable entry / Transmitter / Connection to neck tube / Neck tube / Thread size / Neck length N (M_H) / Insertion length A (l₁), A (U₂) / Measuring insert diameter Ø d / Measuring insert sheath material / Certificates / Options

© 12/2003 WIKA Alexander Wiegand SE & Co. KG, all rights reserved.
The specifications given in this document represent the state of engineering at the time of publishing.
We reserve the right to make modifications to the specifications and materials.

